

UTILITY REQUIREMENTS

Ⓧ — DRAIN — (1) @ 1-1/2" NPT

FOR APPROVAL ONLY

ONE (1) SET OF APPROVAL PRINTS MUST BE SIGNED AND RETURNED TO TBJ INC. BEFORE EQUIPMENT CAN BE RELEASED FOR PRODUCTION

- APPROVED AS DRAWN FOR FABRICATION
- NOT APPROVED — REVISE & RESUBMIT FOR FINAL APPROVAL

SIGNED _____

DATE _____

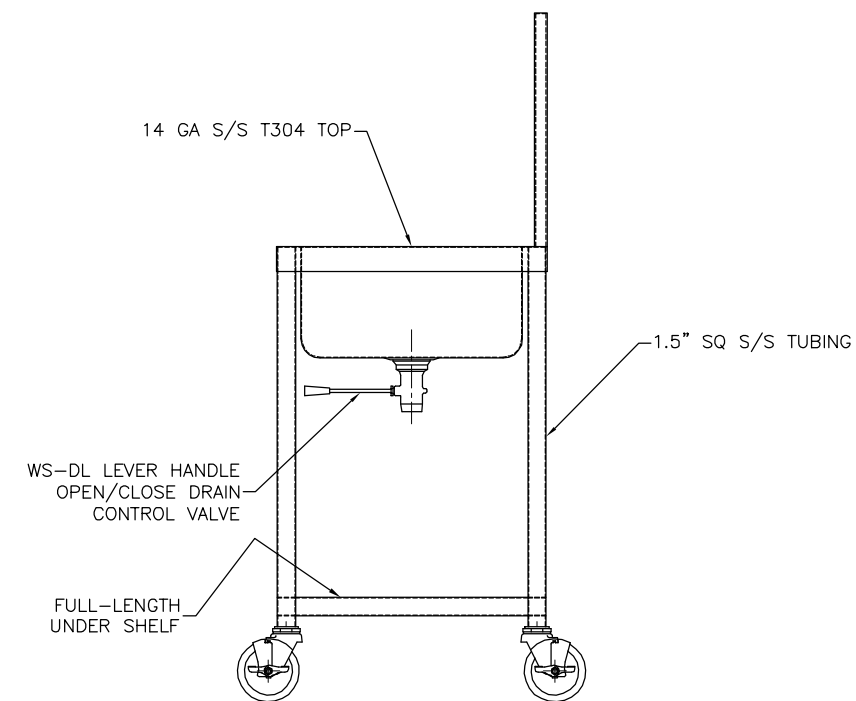
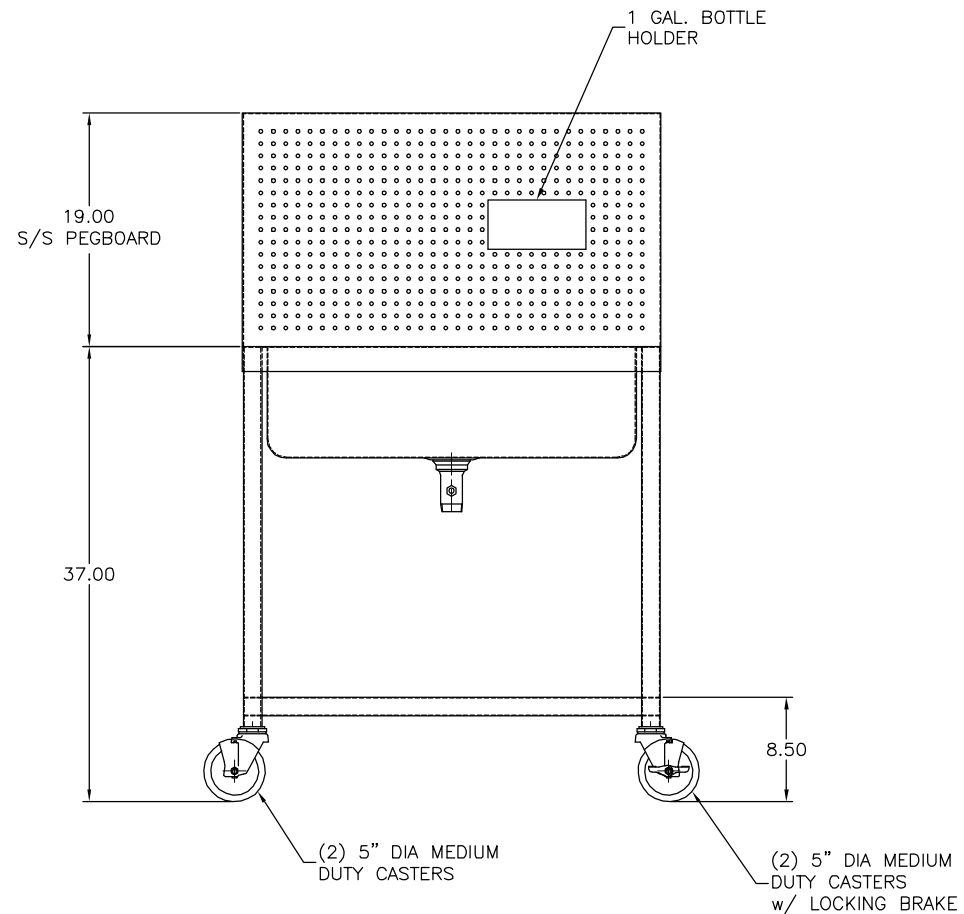

UNLESS OTHERWISE SPECIFIED		LET	REVISION	BY	DATE
TOLERANCES IN INCHES: FRACTIONAL ± 1/32 ANGULAR ± 0°25' ONE DECIMAL ± 0.063 TWO DECIMAL ± 0.031 THREE DECIMAL ± 0.015		 1671 ORCHARD DRIVE CHAMBERSBURG, PA 17201 Phone: (717) 261-9700 www.tbjinc.com			
PRDD. RELEASE	NAME	DATE	SCALE 1-1/2"=1'-0"	DRAWN BY SMH	
APPR. RELEASE			REF DWG -	DATE 4-30-21	
REVIEWED BY			22-34-1B WS-M MOBILE WORK SINK		
ENG APPR.			ROUGH-IN ASSEMBLY		R21107