

UTILITY REQUIREMENTS

ⓔ — ELECTRICAL — 115 V., 1 PH., 60 Hz., 15 AMP

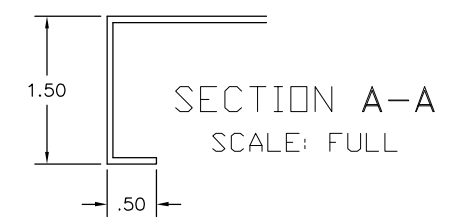

FOR APPROVAL ONLY

ONE (1) SET OF APPROVAL PRINTS MUST BE SIGNED AND RETURNED TO TBJ INC. BEFORE EQUIPMENT CAN BE RELEASED FOR PRODUCTION

APPROVED AS DRAWN FOR FABRICATION

NOT APPROVED — REVISE & RESUBMIT FOR FINAL APPROVAL

SIGNED _____

DATE _____

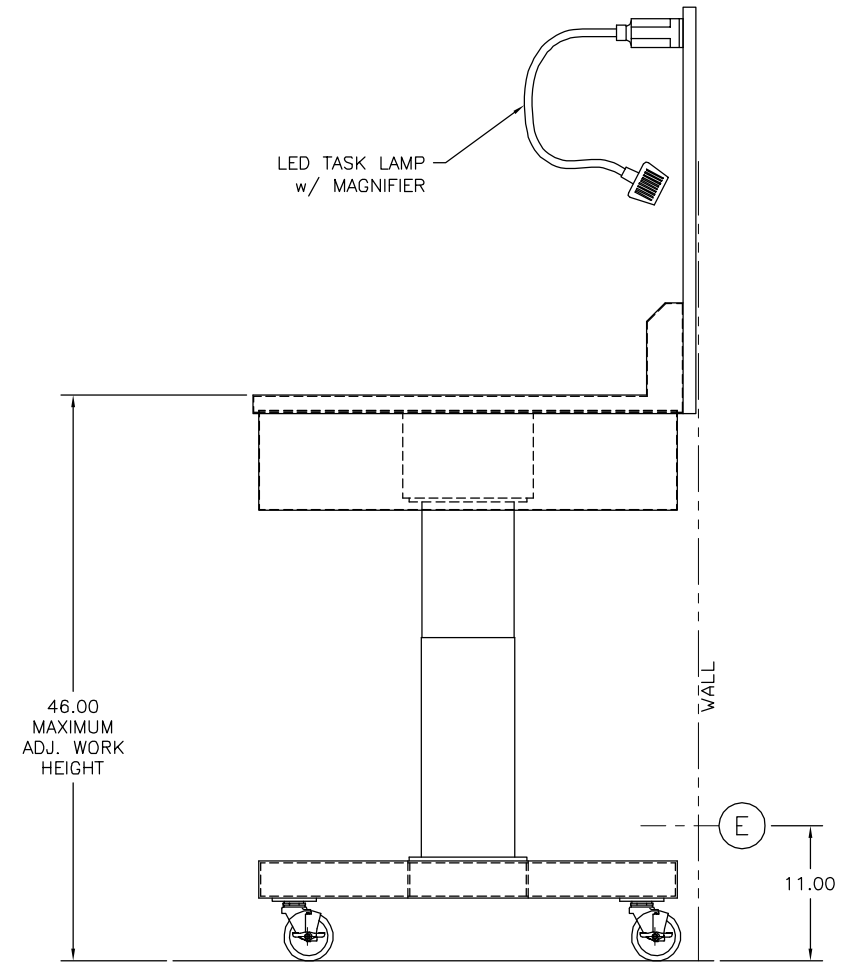
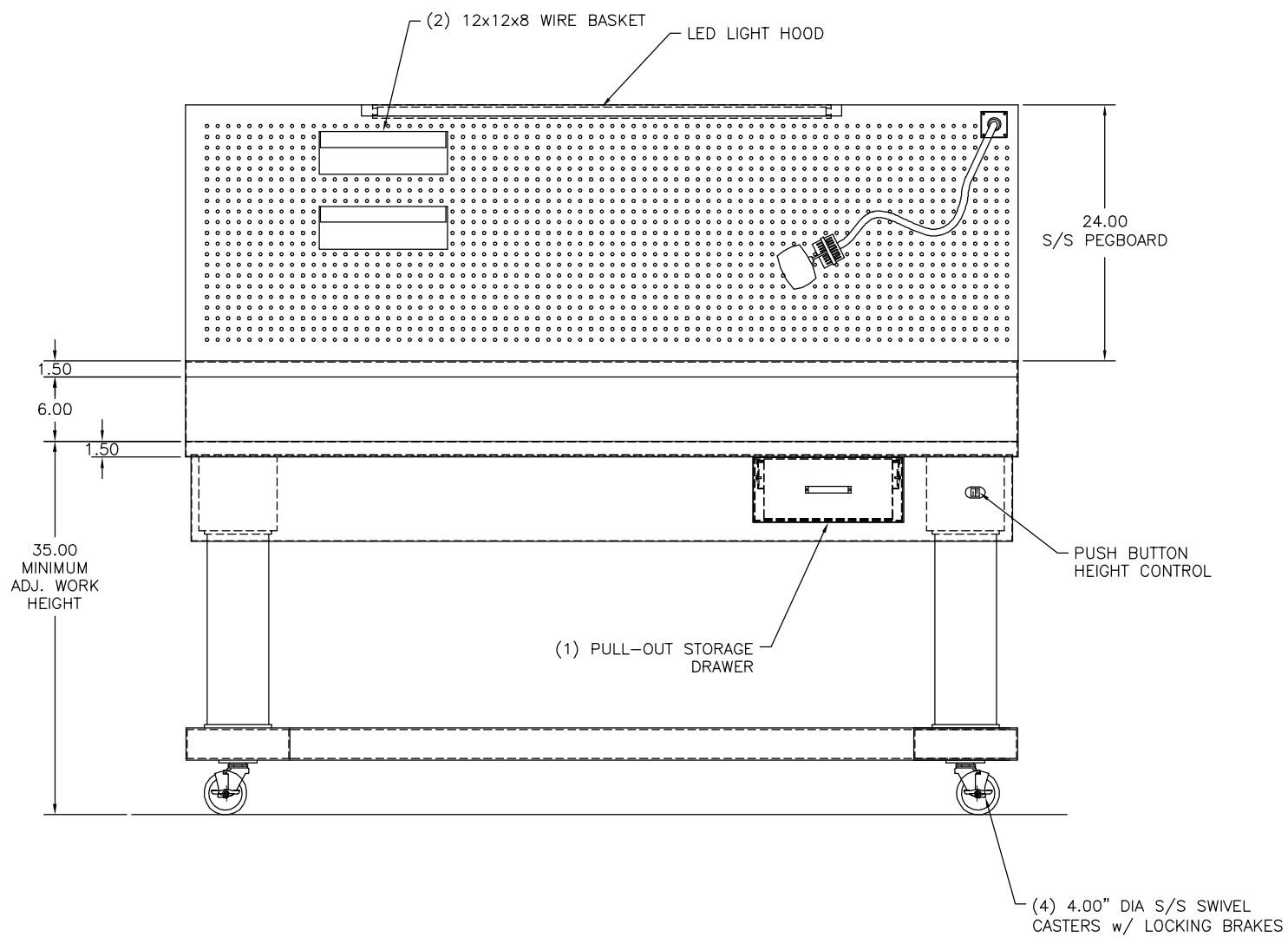

NOTES: 1. MAX. OVERALL DIMENSIONS MUST BE CONSIDERED FOR BUILDING ENTRY.

NOTE:
 - INCLUDED BUT NOT SHOWN: (12) 7"x12"x4" PLASTIC BINS
 - ELECTRICAL BREAKER BOX MOUNTED UNDER TABLE TOP;
 INCLUDES 8' POWER CORD

UNLESS OTHERWISE SPECIFIED		-		-	
TOLERANCES IN INCHES: FRACTIONAL ± 1/32 ANGULAR ± 0°25' ONE DECIMAL ± 0.063 TWO DECIMAL ± 0.031 THREE DECIMAL ± 0.015		LET	REVISION	BY	DATE
				1671 ORCHARD DRIVE CHAMBERSBURG, PA 17201 Phone: (717) 261-9700 www.tbjinc.com	
		SCALE 1-1/2"=1'-0"	3310-1	DRAWN BY SMH	
		REF DWG - R19208		DATE 9-19-19	
PRDD. RELEASE	-	36-78 PPT-AH-MOD - PREP-PACK TABLE			
APPR. RELEASE	-	ROUGH-IN ASSEMBLY			
REVIEWED BY		R19283			
ENG APPR.					