

CLEARANCE HOLE FOR
1/4-20 HARDWARE (BY OTHERS)
(2) PLCS

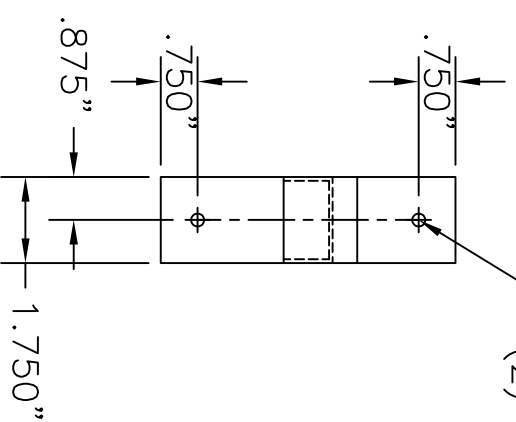

FOR APPROVAL ONLY

ONE (1) SET OF APPROVAL PRINTS MUST BE SIGNED AND RETURNED TO TBJ INC. BEFORE EQUIPMENT CAN BE RELEASED FOR PRODUCTION

APPROVED AS DRAWN FOR FABRICATION

NOT APPROVED - REVISE & RESUBMIT FOR FINAL APPROVAL

SIGNED _____

DATE _____

UNLESS OTHERWISE SPECIFIED			
TOLERANCES IN INCHES:			
FRACTIONAL ± 1/32			
ANGULAR ± 0.25°			
ONE DECIMAL ± 0.063			
TWO DECIMAL ± 0.031			
THREE DECIMAL ± 0.015			
REF	DWG	NAME	DATE
PRD	REL		
APPR	REL		
REV	BY		
ENG	APP		
SCALE 6'-1'-0"		DRAWN BY SMH	
DATE		DATE	
INSTRUMENT STRINGER ARM		BY DATE	
ROUGH-IN ASSEMBLY		R18111	

1671 ORCHARD DRIVE
CHAMBERSBURG, PA 17201
PHONE (717) 261-9700 WWW.TBJINC.COM